

EZ-PATH®

FIRE STOPPING GROMMET

Legrand's EZ-Path® grommet provides fire stopping for individual and small bundles of cables through fire rated, solid or partition walls. The device is moulded from premium plenum plastic and incorporates an intumescent foam core, ensuring fire stopping for up to two hours.

Simply place the cables in one side of the grommet then snap together to create a fire stopping solution without the need for sealants, insulated fire sleeves or intumescent putty.

Applications include:

- Digital TV cables within multi-dwelling buildings
- Alarm and security system cables
- Data and fibre optic cables



El 120 fire rating



Fire Alarm
Detection



CCTV
Security



Emergency
Lighting





Satellite
TV

 **legrand®**

EZ-Path

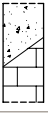
fire stopping grommet

Standard certification			Fire resistance classification	
			Flexible wall	Rigid wall
Fire resistance : EN 1366-3			≥ 100 mm	≥ 100 mm
Classification : EN 13501-2				
EZ-Path grommet	Cat. Nos.	Ø cables (mm)		
	1 x CM350705 (1 x RFG2)	OD ≤ Ø 14	EI120	EI120

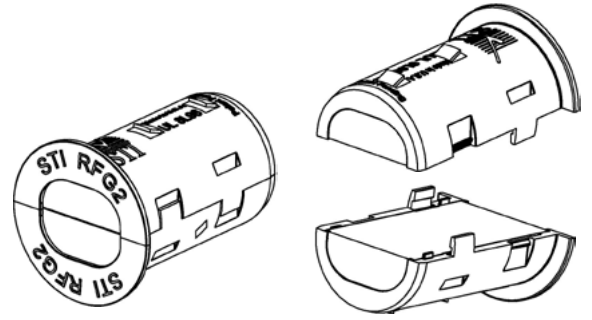

■ Installation instructions

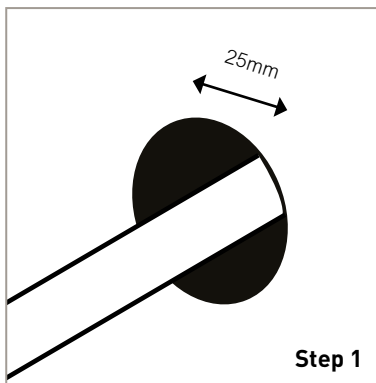

Drill a 25mm diameter hole

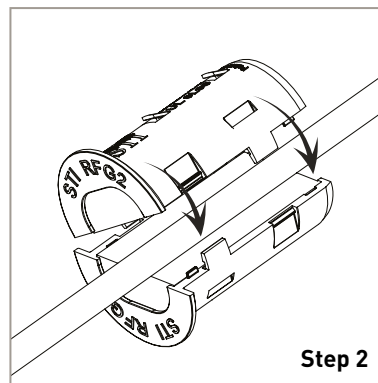

Clip the two halves of the grommet together around the cable(s)

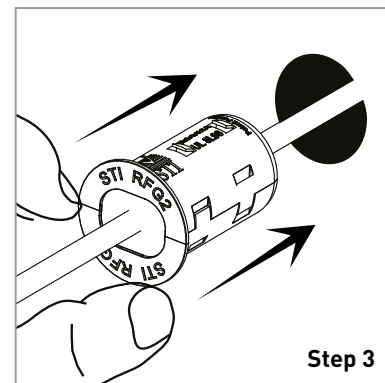

Push the sealed grommet firmly into the drilled hole

Contact details

Customer Services:

Tel: +44 (0) 345 605 4333 Fax: +44 (0) 345 605 4334
E-mail: legrand.sales@legrand.co.uk

Quotations and Technical Support:

Tel: +44 (0) 370 608 9020 Fax: +44 (0) 345 605 5334
E-mail: uk-cmsales@legrand.co.uk

Republic of Ireland:

Tel: 01 295 9673 Fax: 01 295 4671
E-mail: legrand.sales@legrand.co.uk

EZ-Path® is a registered trademark and is manufactured by Specified Technologies Inc. (STI)

In accordance with its policy of continuous improvement, the Company reserves the right to change specifications and designs without notice. All illustrations, descriptions, dimensions and weights in this catalogue are for guidance and cannot be held binding on the Company. All contents and design presentation included in this publication are © Legrand Electric Limited. All rights reserved. 2018



This document is printed on sustainably sourced paper. Please recycle.



Head office (UK and Ireland):

Legrand Electric Limited
Great King Street North, Birmingham, B19 2LF
Tel: +44 (0) 370 608 9000 Fax: +44 (0) 370 608 9004
Website: www.legrand.co.uk

FOLLOW US AT:

 www.twitter.com/legranduk

 www.linkedin.com/company/legranduk

 www.youtube.com/legrandtvuk

The Legrand logo is a registered trademark of the Legrand group of companies.