



DUNASFERN
Inc. **AURIGA**

Outdoor Wall Mounting Cabinets



DUNASFERN
Inc. **AURIGA**

600mm wide IP55 Outdoor Wall Mounting Cabinets

The IP55 Outdoor Wall Mounting Cabinets are designed for industrial applications. Based on EN60529 providing IP55 protection against dust and water ingress.

Applications include open areas subjected to falling dirt and wind blown dust particles, rain, snow or splashing water.

Fully gasketed door, with 3 point locking system, isolated cable entries provide protection against water and dust ingress. 1.5mm thick monoblock welded construction, with Epoxy Polyester type powder coating to RAL 7035 Light Grey colour, providing corrosion resistance.

Fresh air filtered inlets to the sides of the cabinet provide natural ventilation. By adding 1 Fan or 2 Fan Modules, forced ventilation can be achieved.



Standards and Compliances



ISO 9001:2008

Quality Management System

EN 61587 -1:2012

Mechanical Structures for
Electronic Equipment

IEC 297-1, 19" mounting

IEC 297-2 Overall cabinet dimensions

EN 60529- IP55 protection class



CE conform to

EN 60950-1:2006

Information Technology
Equipment – Safety – Part-1-
General Requirements



Environment Friendly

*Environmental awareness

*RoHS compliancy

*% 100 Recyclable Material



Specification

- Width = 600mm
- Depth = 450/600mm
- 4 different Standard U heights:
7U, 9U, 12U & 16U
- Load Capacity: 100kgs.
- Standard colour: RAL 7035 Light Grey

IP55 19" Outdoor Wall Mounting series Enclosures width 600mm and depth 450/600mm, in 4 different 'U' heights, gives a wide selection for users.

IP55 Outdoor Wall Mounting Cabinets

Construction Details

- Integrated Fan Filter Housings create fresh air inlets, performing to IP54 protection against water and dust ingress. With the metal cap in place the enclosure is protected against splashing water.
- The fitted roof Canopy provides IP54 protection covering the optional 1 or 2 Fan Modules on the ABS Grill Housing. A series of louvred vents along the front edge allows hot air to escape. See options of hot air removal on drawings.
- The cast Iron Handle with 3 point locking system provides security and anti-vandal protection.
- IP55 conforming cable entry points, multiple access with 2xPG21, 1xPG48 integrated cable entry points, 2x28mm diameter PVC Blind cap.
- Grounded front door to the main body with yellow/green 4.0mm diameter copper wire.
- The front door has a strengthening bar welded on the inside for extra security.
- The 19" mounting rails are double angle and printed with 'U' heights both ways, enabling the user to count from top down or vice versa. They are made from 1.5mm steel with Zinc plating for corrosion resistance, supplied to the front of the cabinets only.



IP55 Outdoor Wall Mounting Cabinets

Construction Drawings

Width: 600 mm

Depth: 450/600 mm

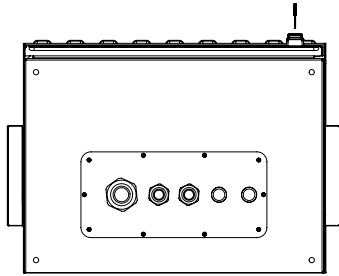

BOTTOM VIEW

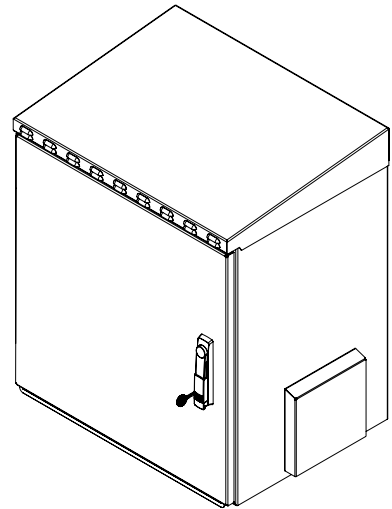

ISOMETRIC VIEW

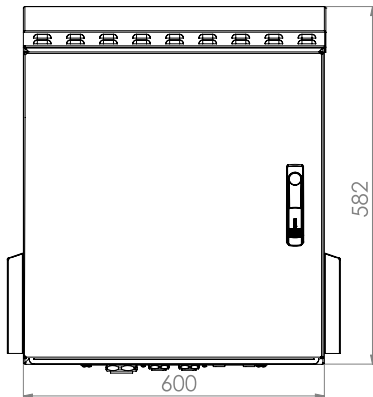

FRONT VIEW

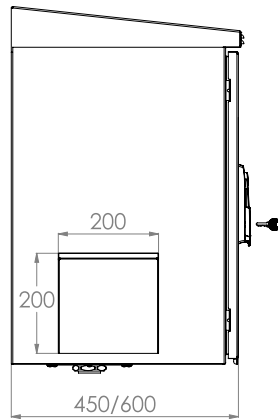

SIDE VIEW

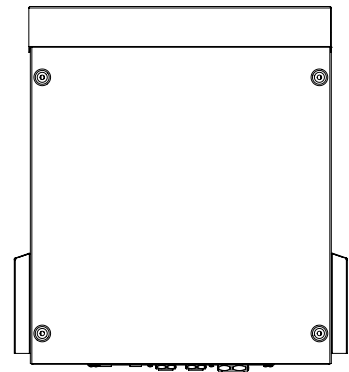

REAR VIEW

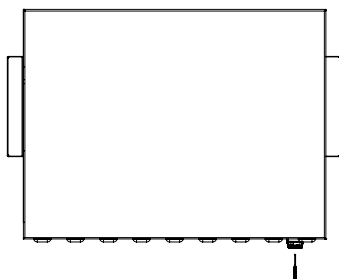

TOP VIEW

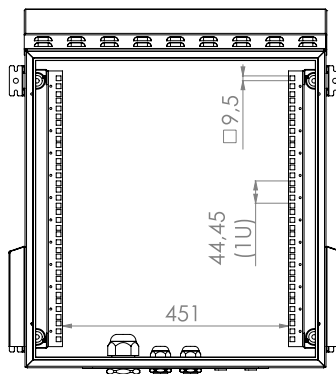

INSIDE VIEW

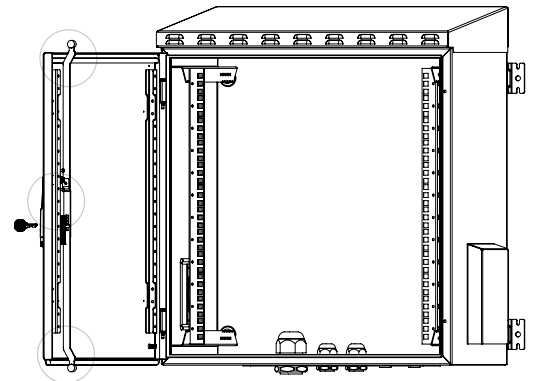

3 POINT LOCKING SYSTEM

IP55 Outdoor Wall Mounting Cabinets

Construction Drawings

Width: 600 mm

Depth: 450/600 mm

OPTION 1

ONE FAN OUT

TWO FILTER INLET

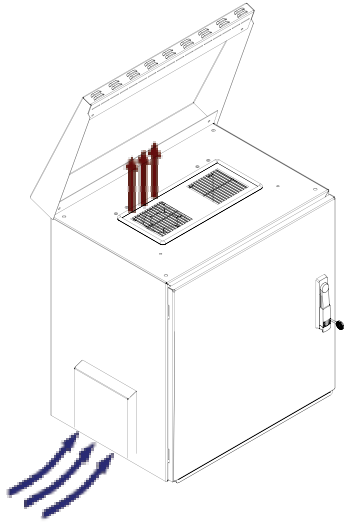

HOT AIR OUTLET

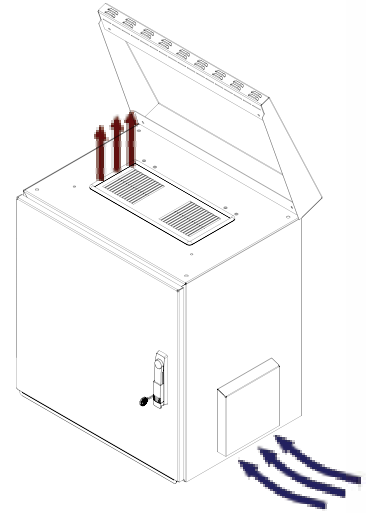
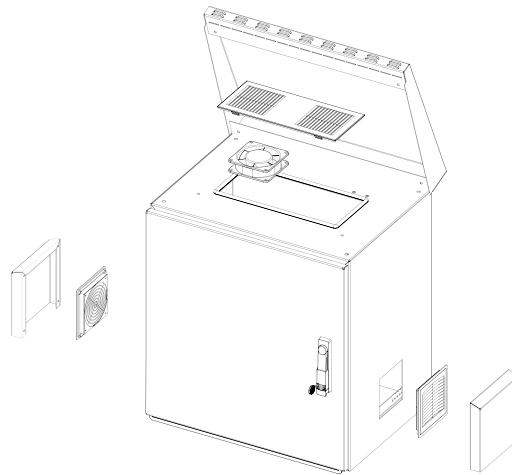

COOL AIR INLET

AIR REMOVAL

OPTION 2

TWO FAN OUT

TWO FILTER INLET

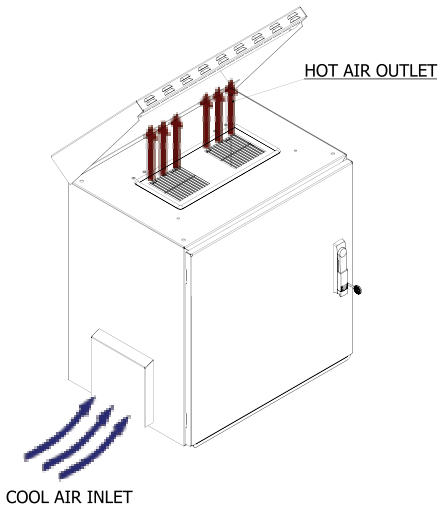

HOT AIR OUTLET

COOL AIR INLET

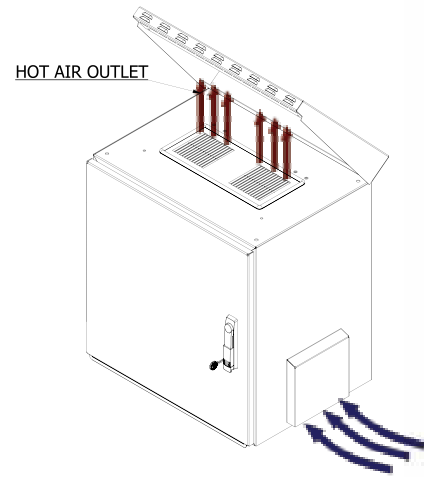
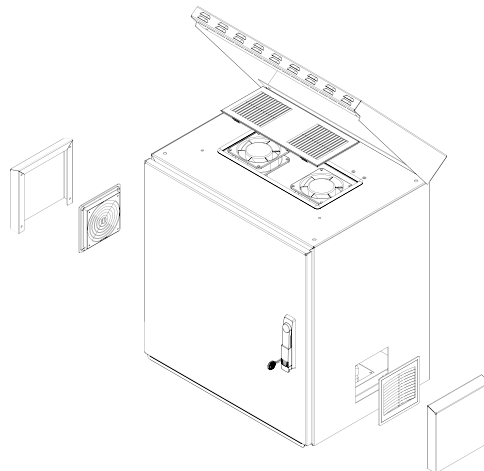

COOL AIR INLET

AIR REMOVAL

IP55 Outdoor Wall Mounting Cabinets

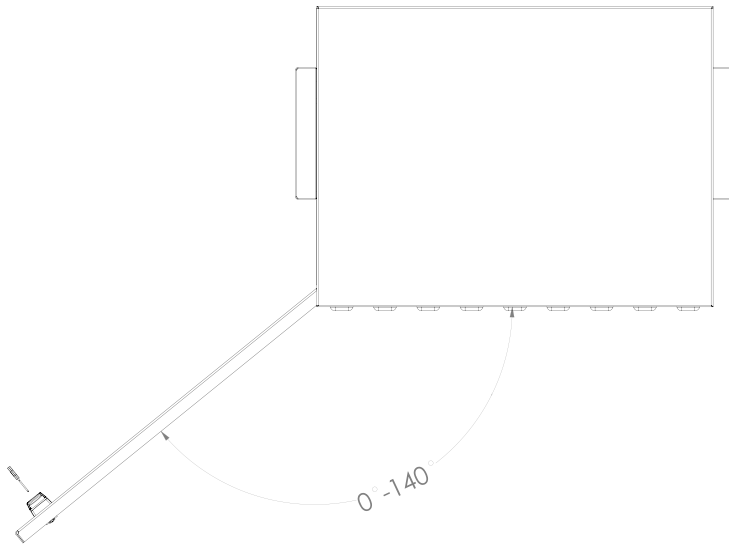

FRONT DOOR OPENING ANGLE

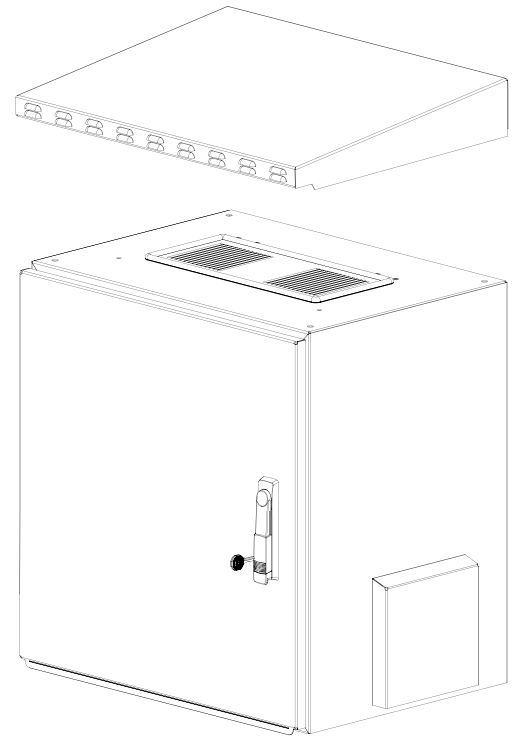

TOP COVER EXPLODED VIEW

IP55 Outdoor Wall Mounting 19" Cabinets

Colour - Paint Light grey RAL 7035

Part Number	Product Description	'U' Height	Height (mm)	Width (mm)	Depth (mm)	Packing Dimensions wxdxh (mm)	Net Weight (kg)	Gross Weight (kg)	
	ENCLOSURE SYSTEMS 4554507/G-L IP55 WALL BOX 7U, 450mm deep, grey 1901	7U	311	600	450	690 x 480 x 510	31	32	
	ENCLOSURE SYSTEMS 4554509/G-L IP55 WALL BOX 9U, 450mm deep, grey	9U	400			690 x 480 x 600	33	34	
	ENCLOSURE SYSTEMS 4554512/G-L IP55 WALL BOX 12U, 450mm deep, grey	12U	533			690 x 480 x 730	37	38	
	ENCLOSURE SYSTEMS 4554516/G-L IP55 WALL BOX 16U, 450mm deep, grey	16U	711			690 x 480 x 910	41	43	
	ENCLOSURE SYSTEMS 4556007/G-L IP55 WALL BOX 7U, 600mm deep, grey	7U	311		600	600	690 x 630 x 510	37	38
	ENCLOSURE SYSTEMS 4556009/G-L IP55 WALL BOX 9U, 600mm deep, grey	9U	400				690 x 630 x 600	40	41
	ENCLOSURE SYSTEMS 4556012/G-L IP55 WALL BOX 12U, 600mm deep, grey	12U	533				690 x 630 x 730	43	45
	ENCLOSURE SYSTEMS 4556016/G-L IP55 WALL BOX 16U, 600mm deep, grey	16U	711				690 x 630 x 910	49	51

Accessories for IP55 Outdoor Wall Mounting Cabinets



FAN MODULES with ANALOG THERMOSTAT

Ready pre-installed, plug-in and run style, with 0-35C operating Analog Thermostat switch and plugs. Each Fan has an air flow capacity of 2,3-3 cbm/min. Fan Technical data: 18/17 W, 220/240 VAC, 50/60 Hz, 0,13/0,11 A, 2300/3000 rpm 42 dB noise level, Fan life: 10.000 hours.

Part Number and Product Description	Product Dimensions (mm)	Pack Dimensions (mm)	Net Weight (kg)	Gross Weight (kg)	Compatible With IP55 Wall Mounting Cabinets	
					600 x 450 (mm)	600 x 600 (mm)
TBC ENCLOSURE SYSTEMS 4550001/G-L FAN MODULE 1 FAN, filtered, switched	346 x 175 x 50	380 x 160 x 60	1,53	1,76	✓	✓
TBC ENCLOSURE SYSTEMS 4550002/G-L FAN MODULE 2 FAN, filtered, switched			1,97	2,20	✓	✓



DUNASFERN
Inc. **AURIGA**