



RG59 B/U 75 Ohm COAX PE Black

Key Features

- High Frequency Low Loss
- Bare Copper Braided Shield
- PE Sheath

Coaxial and Specialist Cable

Part No: See Below

General Description:

High quality RG Type Coaxial Cable 75 Ohm is specifically suited to broadcast and CCTV installation and is appropriate for numerous other applications. RG59 PE is suitable for installation in ducts, the PE jacket provides extra protection against the ingress of water.

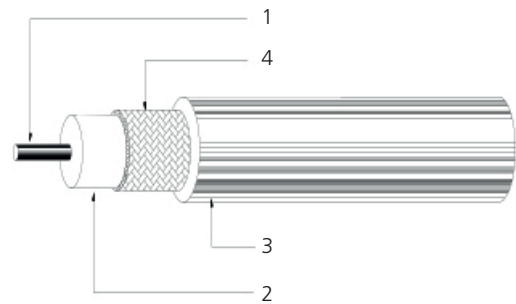

Relevant Test Standards:

UL1581 and UL444

Part Numbers

TRI-000159	RG59 B/U 75 Ohm Coax PE Black - Per Metre
TRI-000159-500	RG59 B/U 75 Ohm Coax PE Black - 500

Cable Construction:

Material Breakdown:

Conductor	Solid Bare Copper	
	Nom. O.D. (mm)	0.58 up +0.010 down -0.010
Dielectric	Material: SPE	Diameter: 3.70+0.18mm
Jacket	External O.D.	6.15mm(+/-0.25mm)
	Surface	Clean / Smooth
	Outer Material	SPE (complies RoHS)
	Colour	Black
	Braid Material	Copper Clad Aluminum
	Braid Nom O.D.(mm)	0.12(+0.008) * 16*4
Braiding	Material	Bare Copper Braided Shield
	Nom O.D.(mm)	0.16(+/-0.008) * 16*7(93%)

**Electrical Characteristics:**

Conductor Resistance	20°C, Conductor DC Resistance	< 7.83 Ω /100M
Insulation DC Resistance	20°C, Insulation DC Resistance	>200 Ω .M
Testing Voltage		2000v
Capacitance (pF/m)		67.5 (+/-5(pF/m)
Rated Temperature		70°C
Impedence	1-100Mhz	75+5 Ω